

COMMERCIAL DATA SHEET

Eco XR

2468
WORKPLACE
APPRECIATION

Billi Eco with XR Remote Dispenser

The opening stanza for the boiling & chilled range of drinking water appliances, the Billi Eco is the pioneer in space saving, energy efficient and environmentally conscious under-bench instantaneous systems. The high performing system is specifically designed for tight spaces, servicing smaller populations requiring fast recovery and is Global GreenTag certified to a Gold standard.

The XR remote dispenser is an innovative and thoughtful design, with the potential for ambulant or wheelchair inclusive access via the remote control panel.



BOILING **CHILLED**



XR Remote Dispenser



Eco Under-Bench Unit



Features



PRODUCT SPECIFICATIONS

Water type	Product code	Model name	Dispenser	Suggested no. of people	Boiling water delivery (cups per hour)*	Chilled water delivery (cups per hour)	Power supply (amps)
  BOILING CHILLED	901000R	Eco	XR Remote	Up to 10	90	60	10

* Based on the initial number of cups of boiling water immediately available, drawn one cup every 10 seconds. For all underbench filtered water systems, consideration may be needed for usage patterns and draw-off methods. 1 cup = 170ml

Accessories

992800 - 70mm Riser & Font

992820 - 70mm Riser

992803 - 120mm Riser & Font

992830 - 120mm Riser



990720 - Tubing Extension Kit for X series dual temp dispensers 2mtrs

Finishes

Standard Finishes

CH - Chrome

Add the Finish code to the Product Code to finalise your specification, eg. 901000RCH

TECHNICAL DRAWING & INSTALLATION REQUIREMENTS

PRODUCT DIMENSIONS

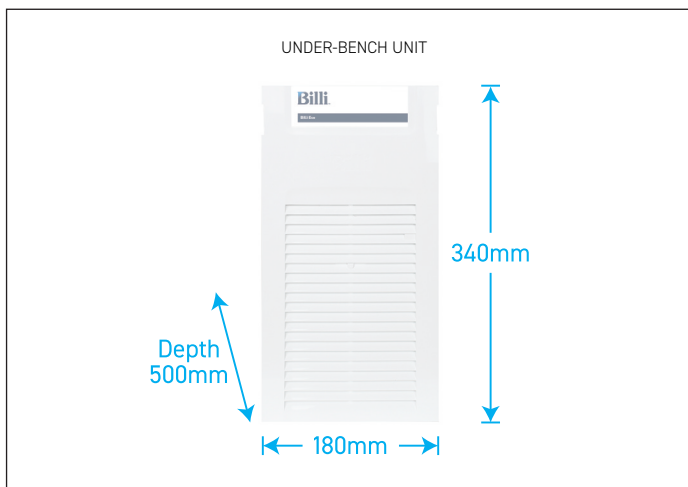
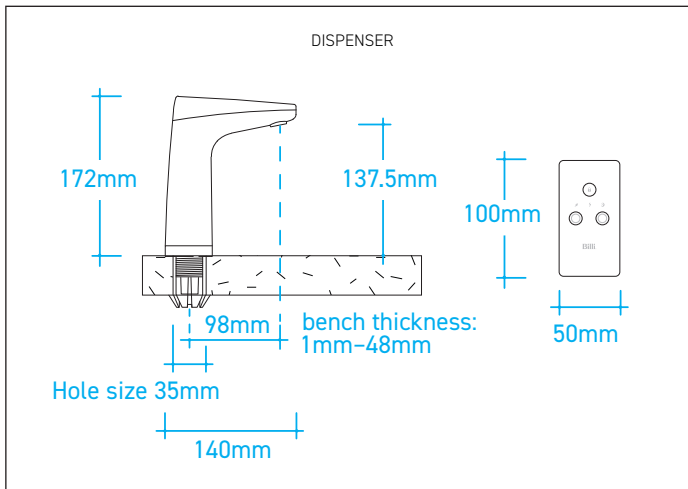

PREFERRED INSTALLATION LAYOUT

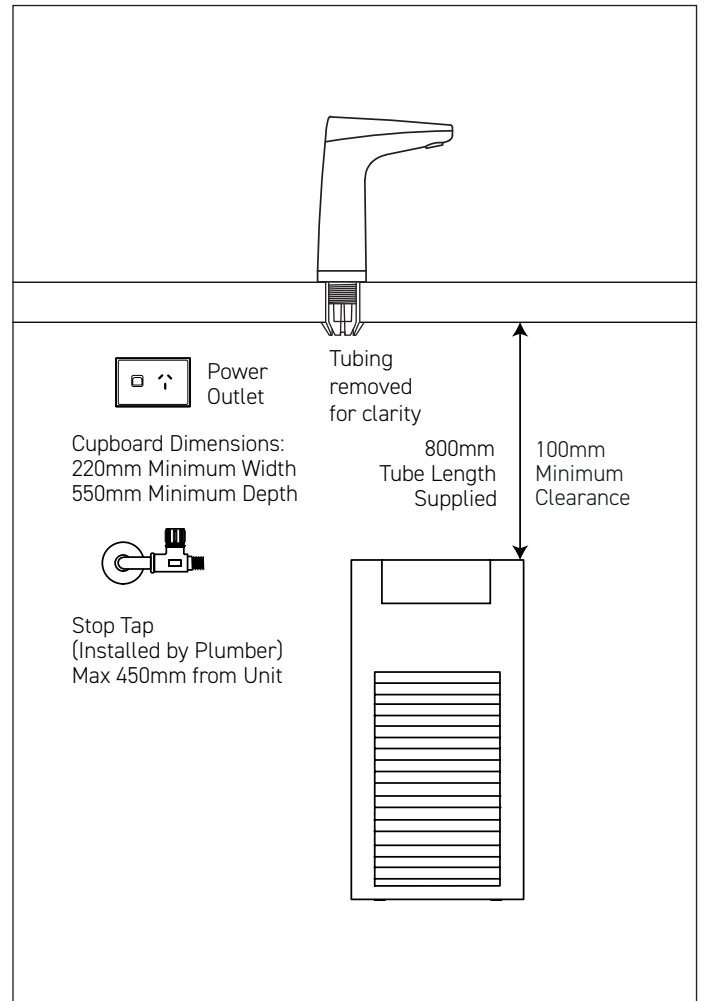

WATER SUPPLY

A single 1/2" BSP (15mm) stop-tap with a male thread should be installed in an easily accessible position. Water supply must be microbiologically safe to drink, with a minimum dynamic water pressure of 250kPa and a maximum of 1000kPa.

POWER SUPPLY

A standard 10 amp power outlet is required, no further than 1000mm from the underbench unit. The system is supplied with a 1 metre flex cord and plug.

FILTRATION

Billi's range of premium filters utilise BWT's unique Fibron X technology. Billi's filter range provides superior taste, water quality, consistent filter life and peace of mind when it comes to hygiene.

Filter supplied: 994051 (5 micron). Replacement filters available: 994052 (0.2 micron), 994054 (HSD), 994055 (XPHSD), 994056 (Sediment only) and 994060 (0.2 micron sediment only).

CERTIFICATIONS

Every Billi drinking water appliance is manufactured under a certified quality control system. All Billi commercial range models have been tested and comply with all required standards including: Watermark: WM-021525; Certified to AS/NZ3498 and AS/NZ 4020; ISO 9001:2015, QEC 11627; Section J6.6 of the BCA; AS1428; Global GreenTag LCARate Gold; WELL Cornerstone Member; HACCP: PE-872-WAT-1-02.

WARRANTY

The Billi Eco range is covered by a comprehensive 2 Year Warranty on all parts and labour.

