

HOME DATA SHEET

B4000 XT

Billi B4000 with XT Touch Dispenser

Instant boiling and still water, the B4000 offers exceptional home convenience and is ideal for making hot drinks and reducing food preparation time with instant boiling water.

The XT touch dispenser is an innovative, contemporary tap which has a touch sensitive operating panel including boiling water safety lock, offering a sophisticated and clean style.

Supplied standard with 994052 sub-micron filtration from BWT to deliver the freshest tasting water and ensure the health of your family & guests.



BOILING

STILL

XT Touch Dispenser

B4000 Under-Bench Unit



Features



SPACE SAVING DESIGN



SAFE TO OPERATE



SPLASHFREE DELIVERY



ENERGY EFFICIENT



NO CUPBOARD VENTILATION REQUIRED



ECO-INTELLIGENCE TECHNOLOGY



AUSTRALIAN DESIGNED & MADE





HACCP CERTIFIED



EASY INSTALLATION

PRODUCT SPECIFICATIONS

Water type	Product code	Model name	Dispenser	Power supply (amps)	Suggested usage
  BOILING STILL	914000T	B4000	XT Touch	10	<ul style="list-style-type: none"> • Drinking water filtration • Cooking & Food preparation • Instant Hot beverages • Sterilisation of baby bottles

* Based on the initial number of cups of boiling water immediately available, drawn one cup every 10 seconds. For all underbench filtered water systems, consideration may be needed for usage patterns and draw-off methods. 1 cup = 170ml

Accessories

992800 - 70mm Riser & Font



992820 - 70mm Riser



992803 - 120mm Riser & Font



992830 - 120mm Riser



990720 - Tubing Extension Kit for X series dual temp dispensers 2mtrs

Finishes

Standard Finishes

CH - Chrome

BR - Brushed

MB - Matte Black

MW - Matte White

Special Order Finish

RG - Rose Gold

Add the Finish code to the Product Code to finalise your specification, eg. 914000TCH

TECHNICAL DRAWING & INSTALLATION REQUIREMENTS

PRODUCT DIMENSIONS

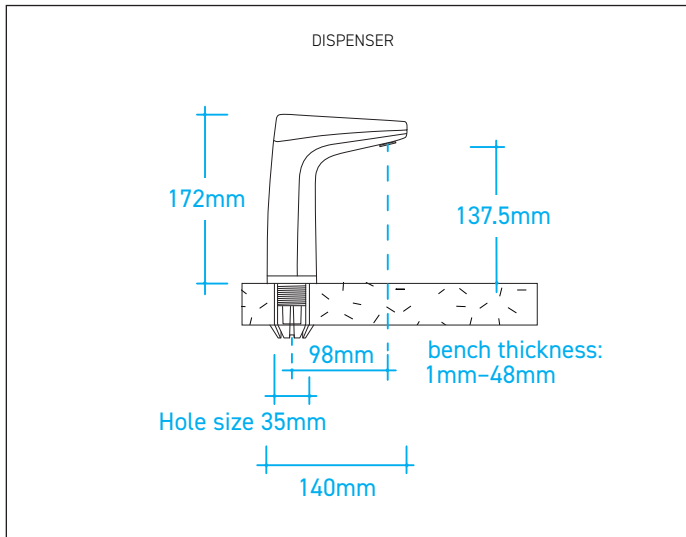

PREFERRED INSTALLATION LAYOUT

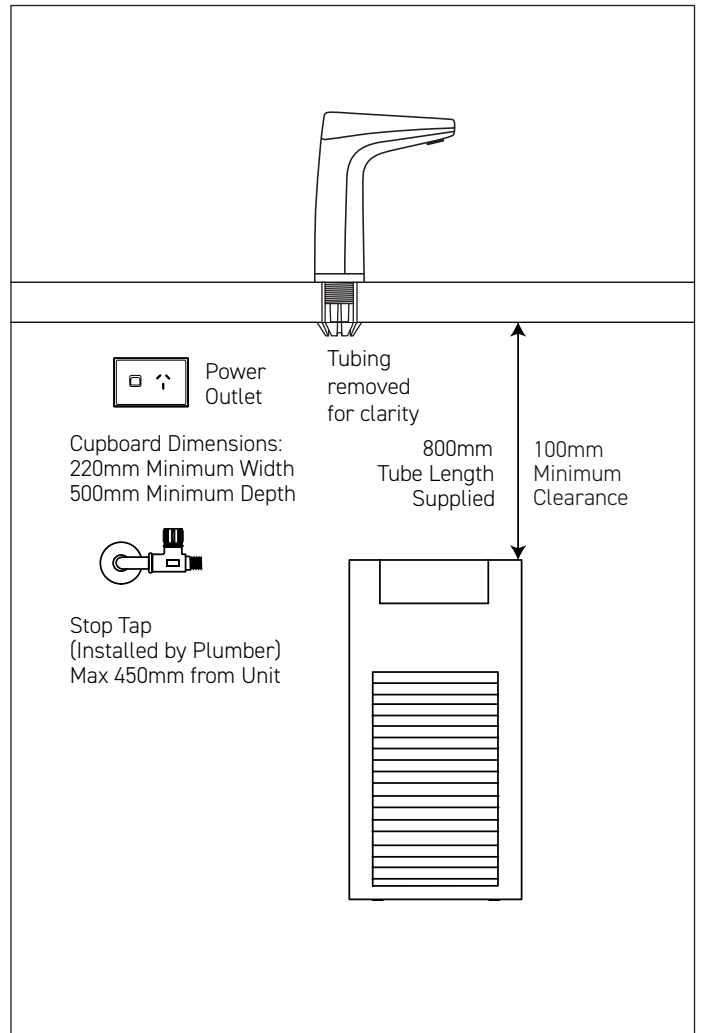

WATER SUPPLY

A single 1/2" BSP (15mm) stop-tap with a male thread should be installed in an easily accessible position. Water supply must be microbiologically safe to drink, with a minimum dynamic water pressure of 250kPa and a maximum of 1000kPa.

POWER SUPPLY

A standard 10 amp power outlet is required, no further than 1000mm from the underbench unit. The system is supplied with a 1 metre flex cord and plug.

FILTRATION

Billi's range of premium filters utilise BWT's unique Fibron X technology. Billi's filter range provides superior taste, water quality, consistent filter life and peace of mind when it comes to hygiene.

Filter supplied: 994052 (0.2 micron). Replacement filters available: 994051 (5 micron option), 994054 (HSD option), 994055 (XPHSD Fibron XP), 994056 (Sediment only) and 994060 (Micron HF Sediment Only).

CERTIFICATIONS

Every Billi drinking water appliance is manufactured under a certified quality control system. All Billi commercial range models have been tested and comply with all required standards including: Watermark: WM-021525; Certified to AS/NZ3498 and AS/NZ 4020; ISO9001:2015, QEC 11627; Section J6.6 of the BCA; HACCP: PE-872-WAT-1-02; WELL Cornerstone Member.

WARRANTY

The Billi B4000 Range is covered by a comprehensive 2 year warranty on all parts and labour.

